

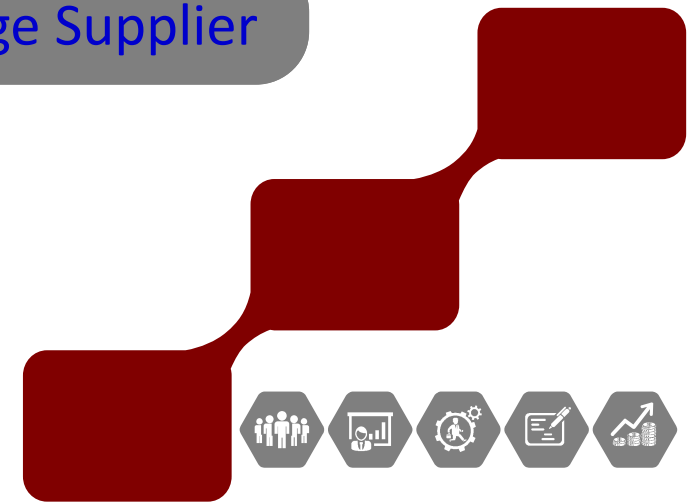

Professional Auto Checking Fixture & Gage Supplier





CONTENTS

- 
- 
- 1 About Us**
 - 2 Equipment**
 - 3 Product Show**

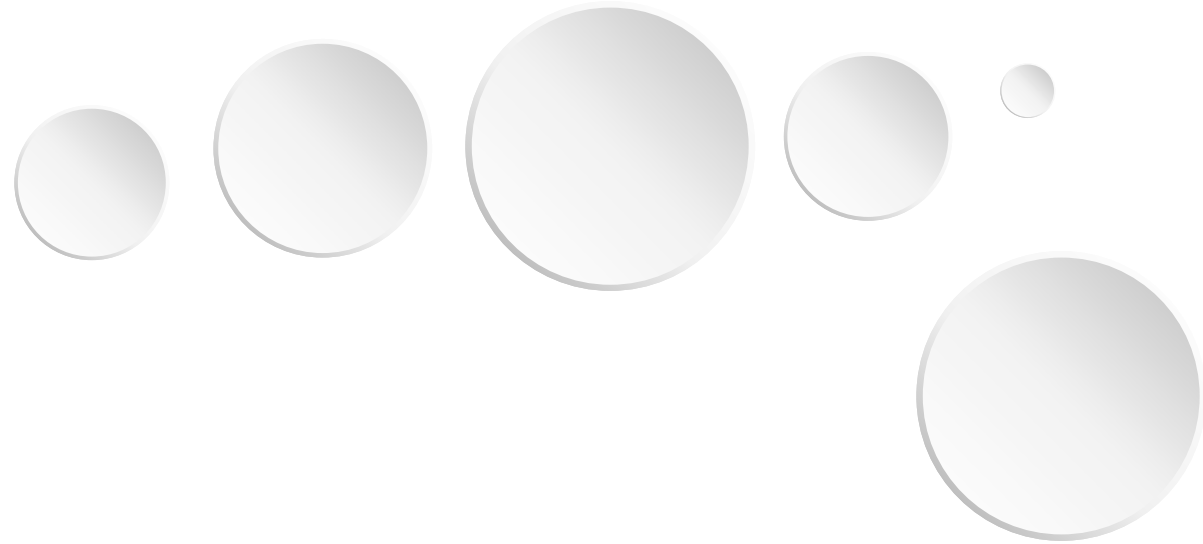

1

About Us

01 : Company Profile

02 : Win Win Culture

03 : Team Work

04 : Quality Control

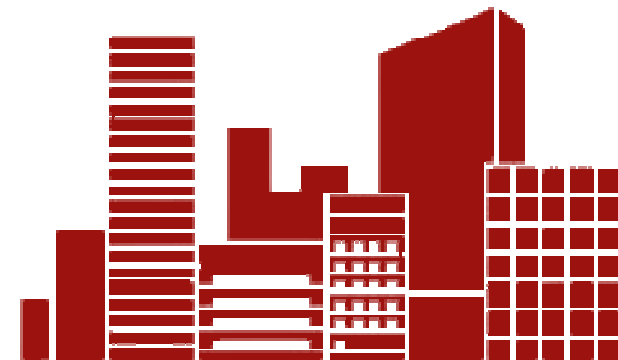
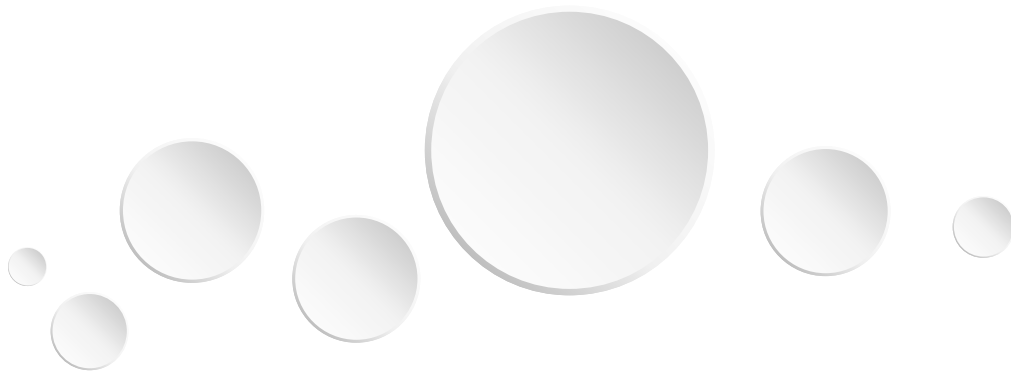



Company Profile

Established in July, 2006;

ISO9001 Certified;

8 experienced designers, totally 40 Plus employees;

Software: CAD, UG NX (Main);

Capacity: averagely 80 sets Plus per Month, around 1000 sets per year;

Win Win Fixture has been focusing on customizing various checking fixture, gages, inspection tools, auto inspection tools, auto parts inspection tools and auto jigs for auto parts factories including Tier 1 & Tier 2 automotive suppliers and auto mold factories for more than 15 years; 2200m² Production workshop, imported equipment, accuracy up to 0.005MM, on-time delivery, 16,000 sets of automobile inspection tools manufacturing experience.

Company Culture



We are a professional team :

Our team members have many years of professional and technical background.

We are a young team :

Our average age is only 36, full of energy and innovation .

We are a dedicated team :

We believe that good products come from the trust of customers. Only by focusing can we better output good products and quality .

We are a team with great dreams :

We come from all over the world, but we share a common dream: to make technology better, to make the company stronger, and to realize common value.

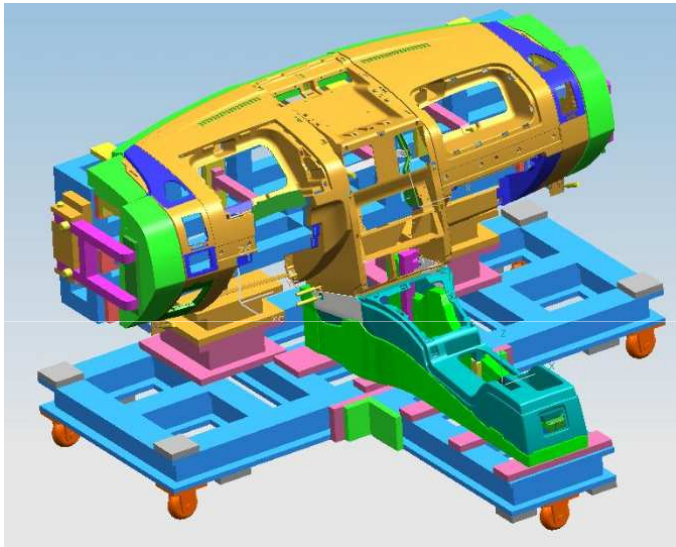

Engineering & Design

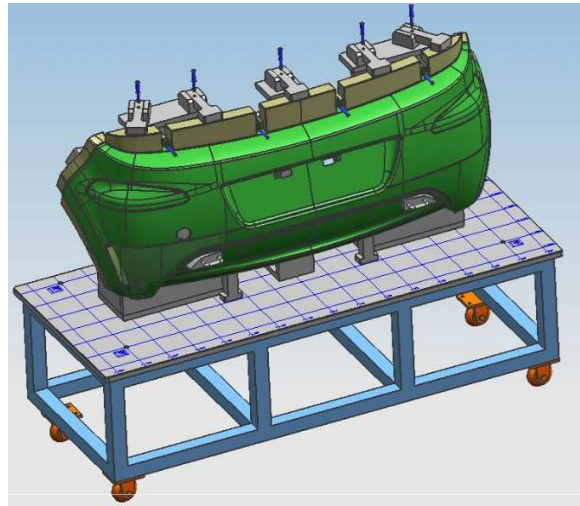

Win Win Fixture implements the talent strategy and has an excellent technical staff team. It has a technology research and development center. It introduces advanced 3D model design and analysis software, and the fixture adopts 3D solid design to realize the inspection and manufacturing CAD/ CAM/CAE three-in-one information management platform. Professional project engineers and fixture designers with more than 10 years of experience work with various customers in numerous industries. Their understanding of tolerance and GD&T come from this experience. Each designer has passed GD& T Training assessment. Quickly respond to customers, provide inspection tool solutions, and draw drawings within 3 hours.

Quality Control

Design Plan & Review

The check fixture/ gage design shall be carried out in strict accordance with the technical standards of GD&T and inspection tools of different customers. And the final review and verification shall be made to ensure the effective implementation and execution of the standards & requirements.

Design

Production Quality Assurance

After machining, the detail processing, all-round dimension measurement and appearance inspection shall be carried out to ensure the conformity and acceptability of check fixture/ gage parts quality

Component Inspection

Complete Check Fixture & Gage Inspection Before Shipping

Complete CF & Gage Inspection & Delivery



Each part of the final check fixture& gage shall be inspected, including (appearance, assembly, size, screw hole, functionality, operability, etc.). Win Win Fixture shall provide a CMM inspection report (in special regions and for some customers, Win Win Fixture will also provide a third-party verification report). And then Win Win Fixture identify, package, and arrange delivery methods according to customer requirements. Win Win Fixture provides customers with one-stop supporting services.

2

Equipment

01 : CNC Machine

02 : Drilling/ Milling/Grinding/Wire Cutting

03 : Gantry CMM

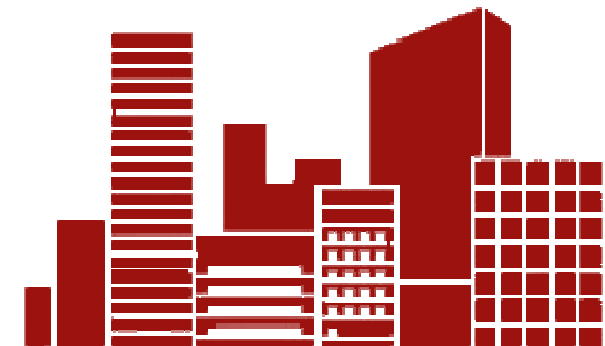

Equipment



● **Drilling/ Milling/Grinding/Wire Cutting**

● **CNC Machining Center**

● **Gantry CMM**

Manufacturing & Debugging

3

Product Show

01 : Checking Fixture

02 : Assembly Fixture/ Gage

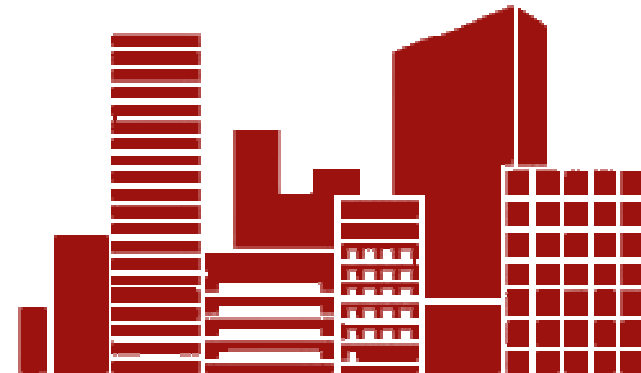

Automobile air outlet
check fixture-1

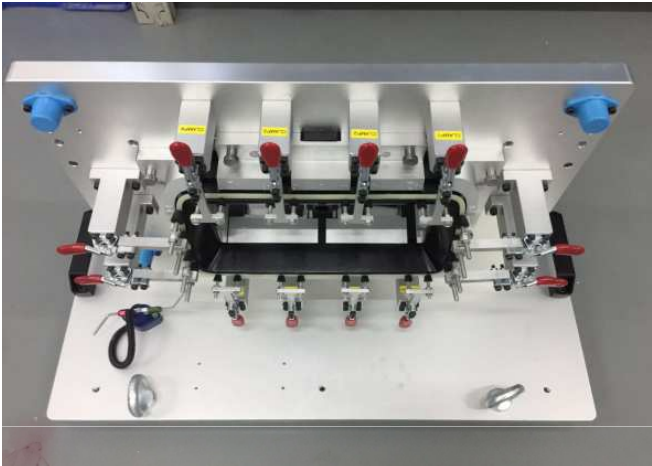

◀ Air outlet

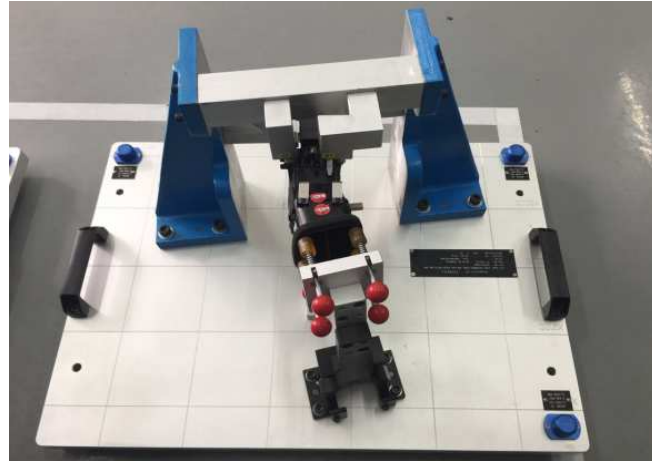

◀ Air outlet

Air outlet ▶

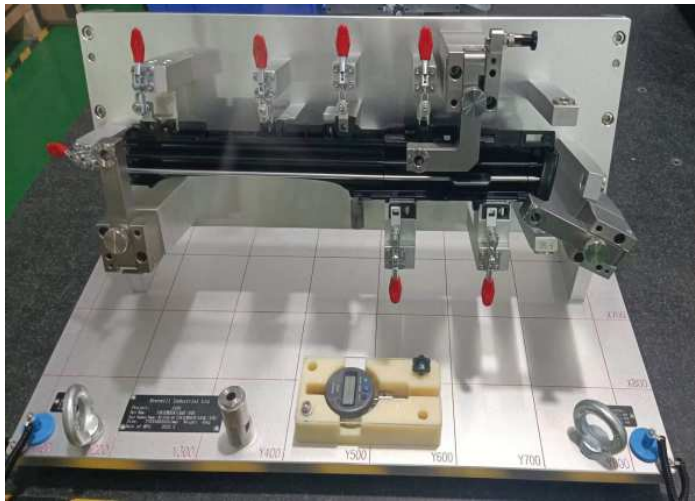

Air outlet ▶

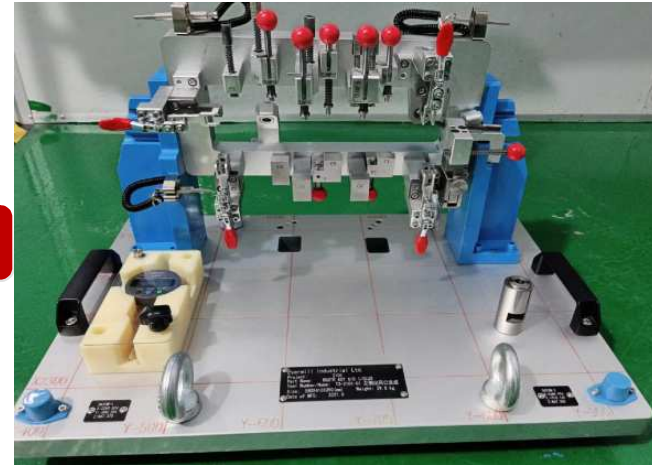

Automobile air outlet
check fixture-2

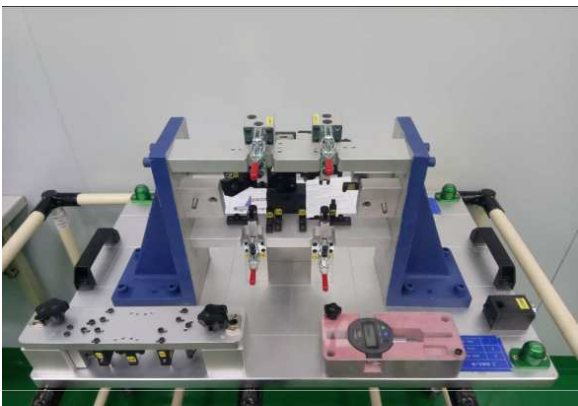

◀ Air outlet



◀ Air outlet

Loudspeaker ▶

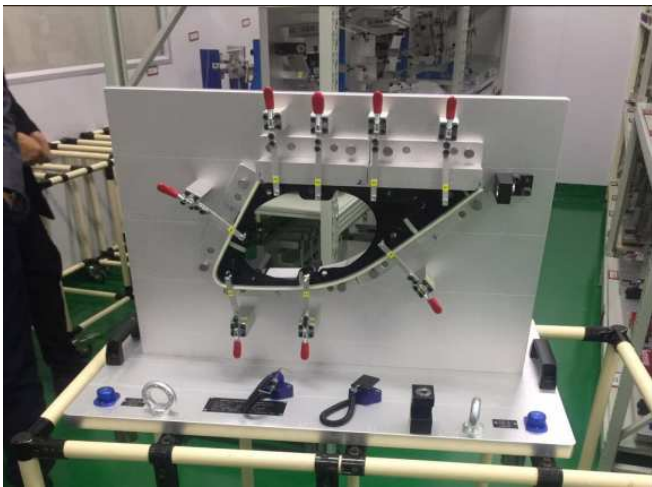

Air outlet ▶



Car central control/storage box checking fixture

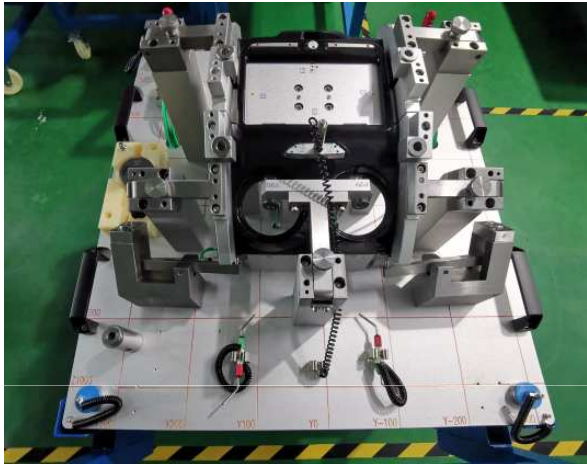

Central control



Central control

Storage box inner plate welding assembly

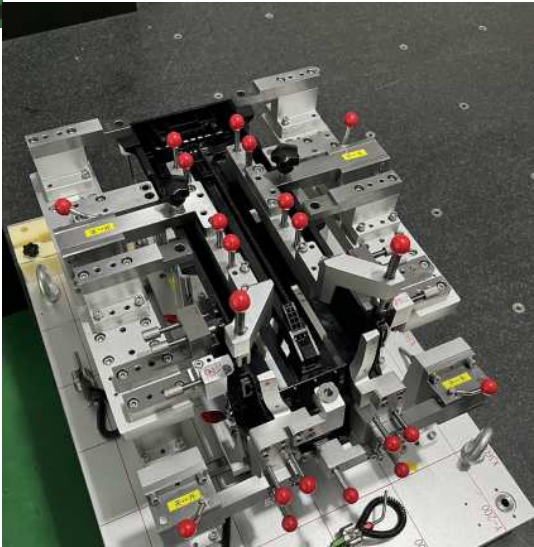

Storage box inner plate welding assembly

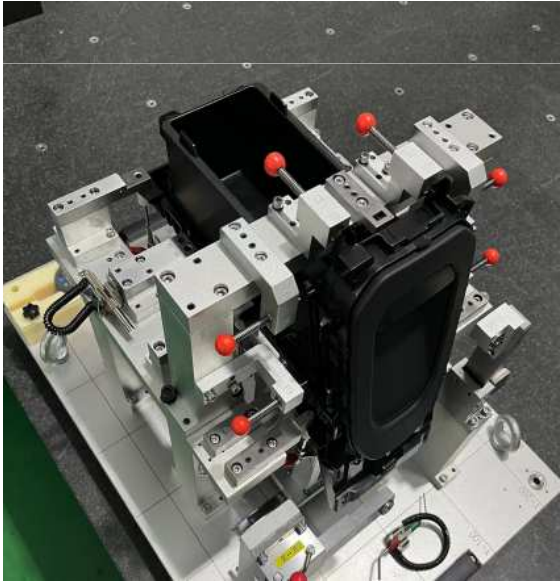

Care Lamp/Light check
fixture



◀ Rear fog lamp



◀ Emergency lamp

Rear lamp ▶



Car lamp ▶



Care bumper & sunroof
check fixture



◀ Front bumper



◀ Rear bumper

Sunroof rail ▶



Sunroof rail ▶

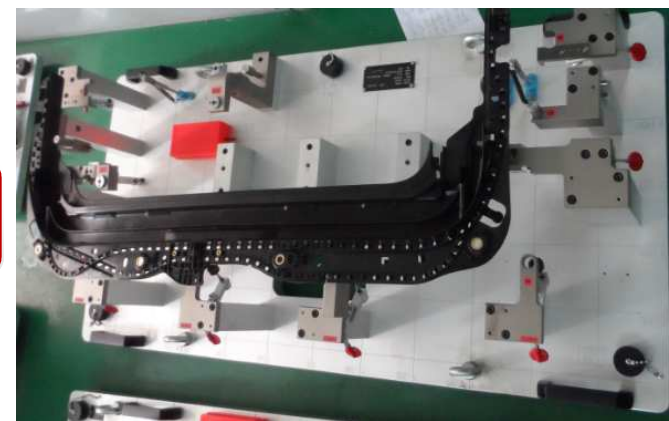

Automobile exterior trim
check fixture (plastic parts)



◀ Door plate

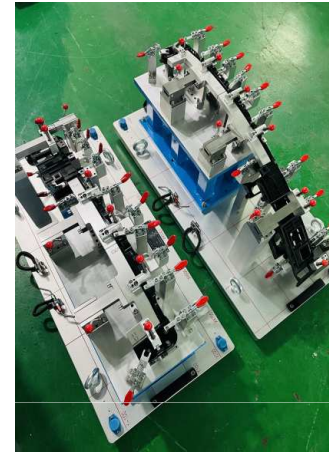

◀ Lamp trim strip

Fuel tank cap ▶

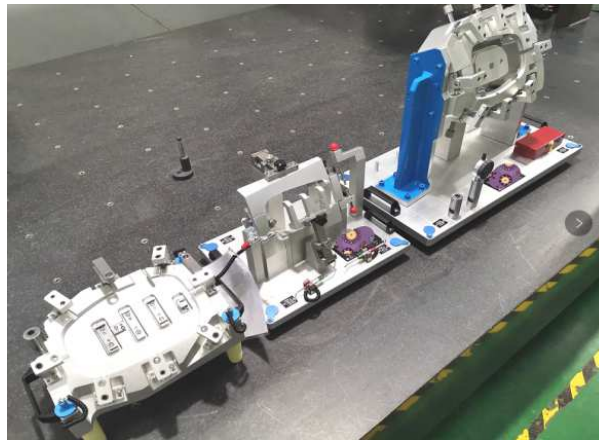

Bumper trim panel ▶



Automobile structural parts check fixture (plastic parts)

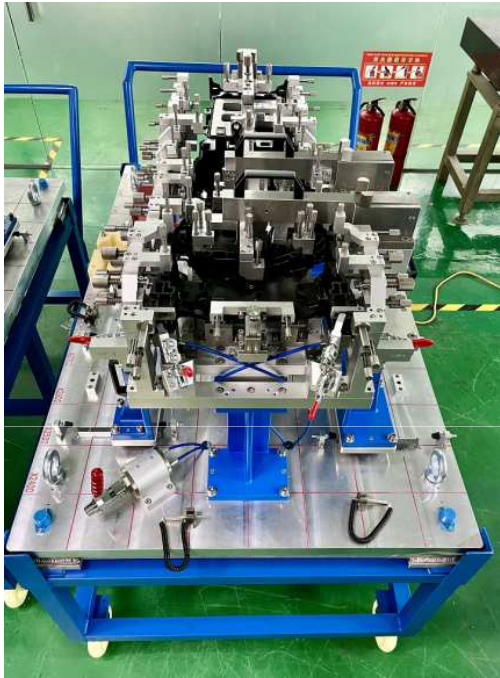

Truck door panel



Air conditioning frame

Central control armrest box



Steering beam



Automobile hardware
check fixture (sheet
metal/stamping)

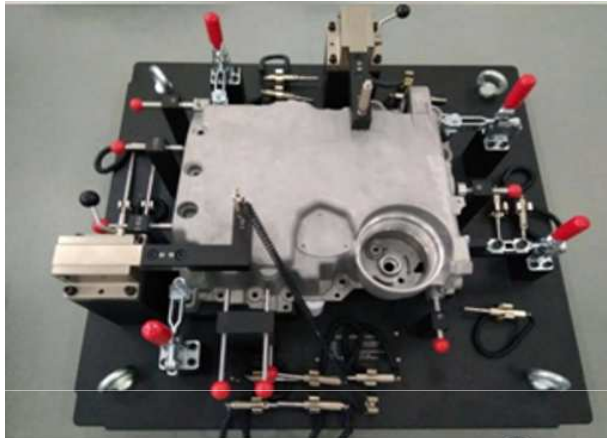

Engine casting



Sheet metal

Sheet metal
guard



Engine
casting



Manual assembly
tooling fixture

Tooling fixture for
automobile parts assembly



Manual assembly tooling fixture for
automobile bumper

Vibration fixture

Tooling fixture for vibration test with minimum weight

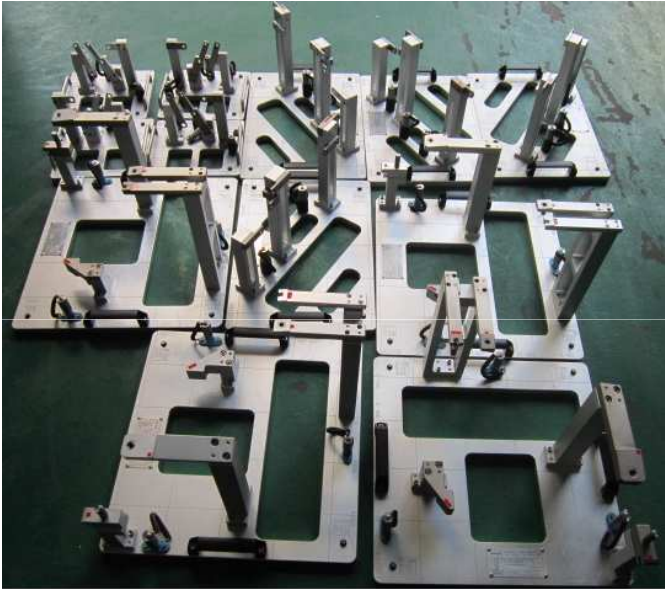



Holding fixture/gage for stress crack resistance test, impact test, CMM inspection etc.

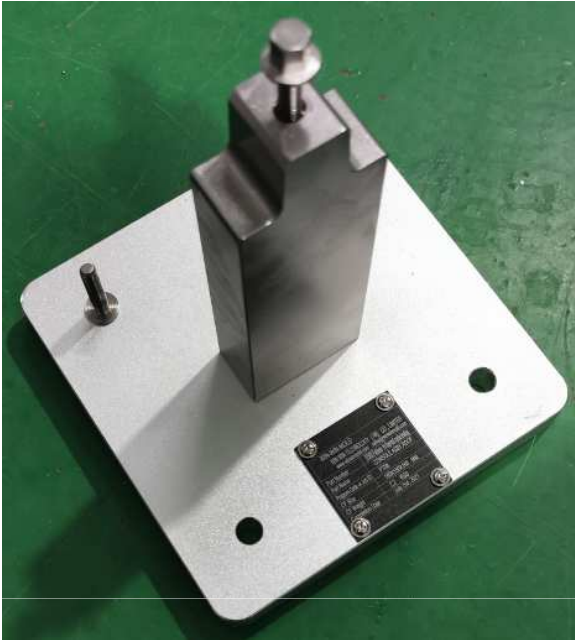
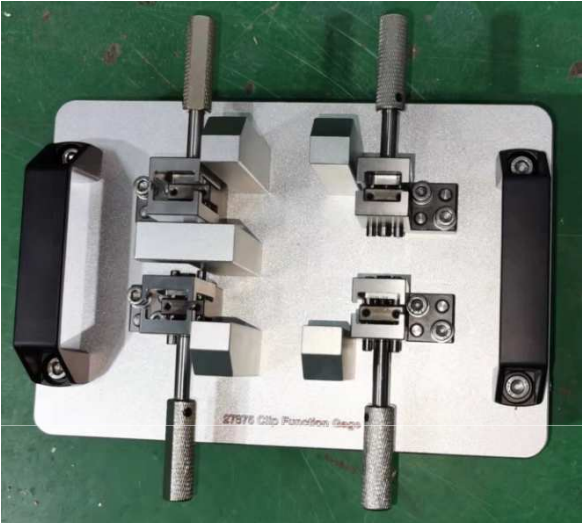

Our Clients

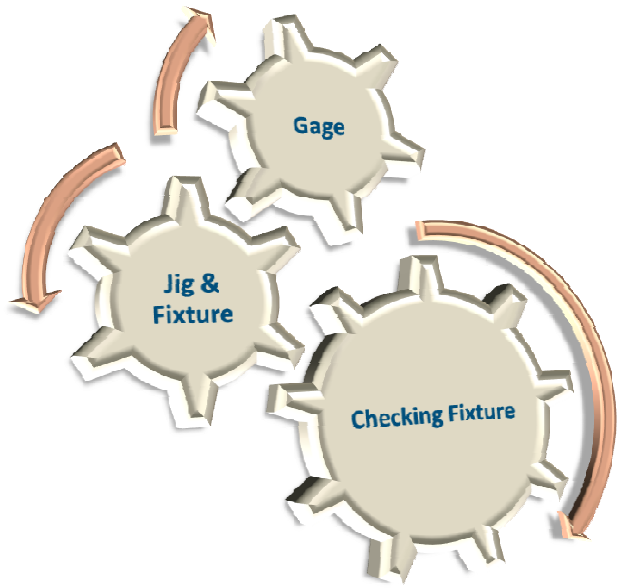
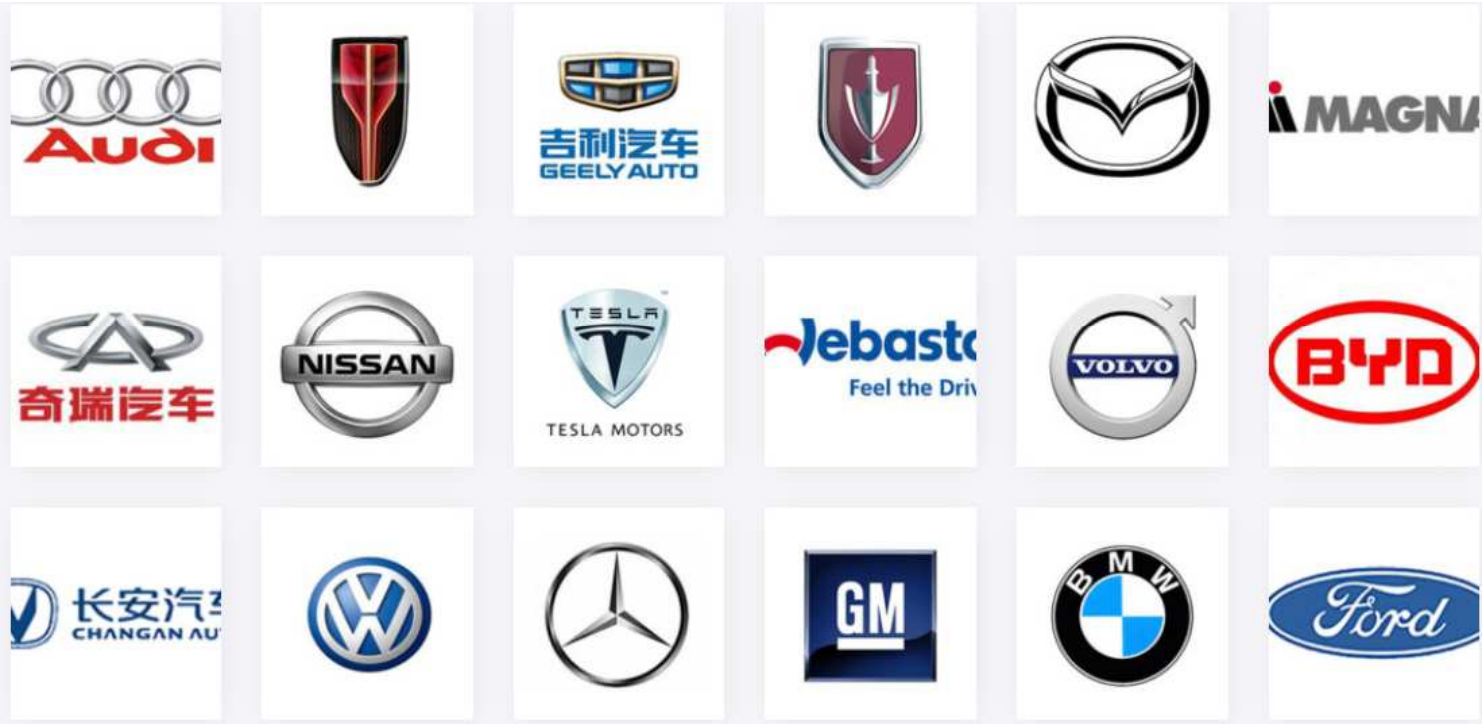



Domestic & Overseas Market

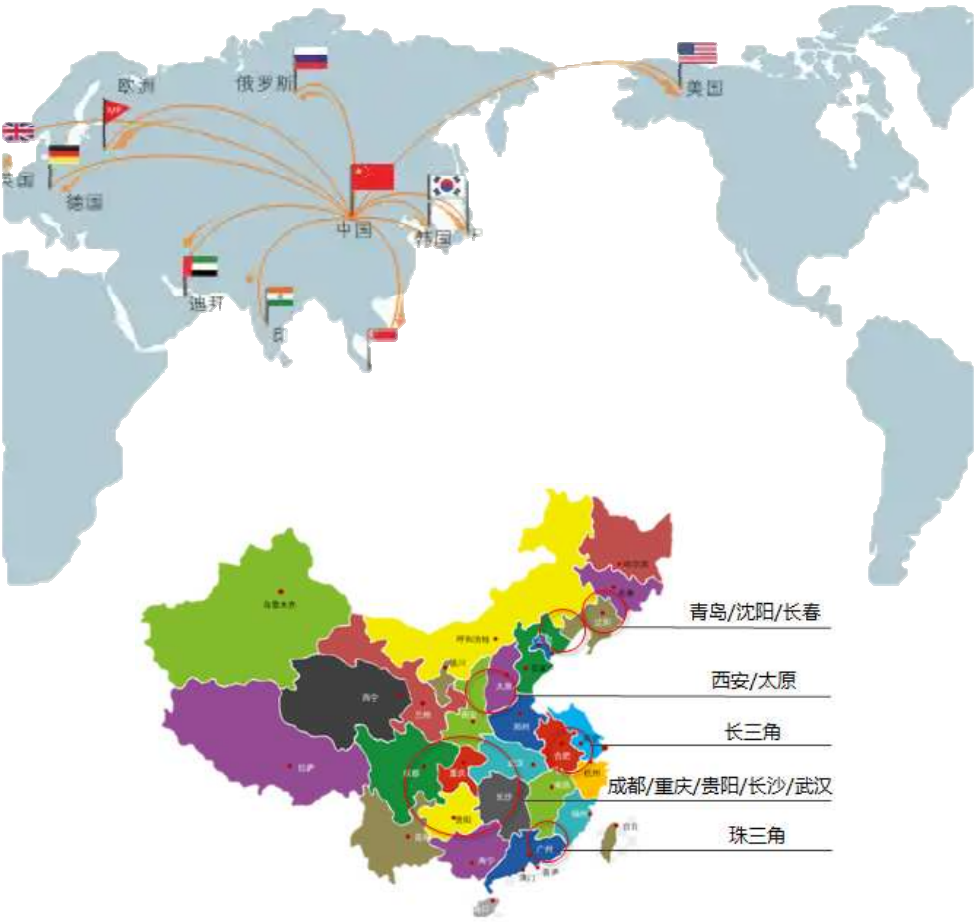

Located in South China, Win Win Fixture has established cooperative relations with customers in North America, Europe. Products and services exported have been well recognized and supported by customers, and a long-term cooperative relationship has been formed.





Contact Us



扫一扫上面的二维码图案，加我为朋友。

Win Win Industrial (Shenzhen) CO., LTD.

Address: No.4 Liyuan Road, Bogang community, Shajing Street Baoan District, Shenzhen, China
518104

E-mail: info@check-fixtures.com

Tel: +86-755-29854960

Mobile: +86-137-9449-9224



Win-Win Cooperation

Thank you!